

E96-216

Bailey®
infi 90

Instruction

Configuration Port Module (IMCPM01)

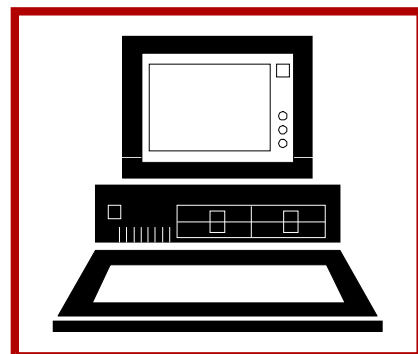
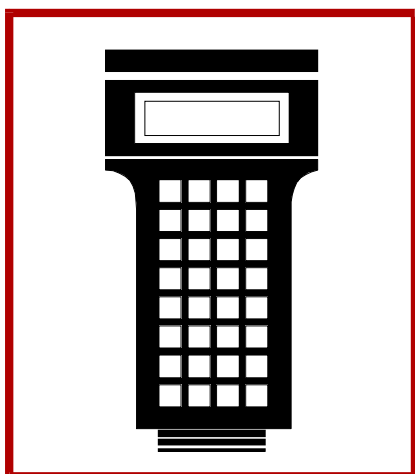
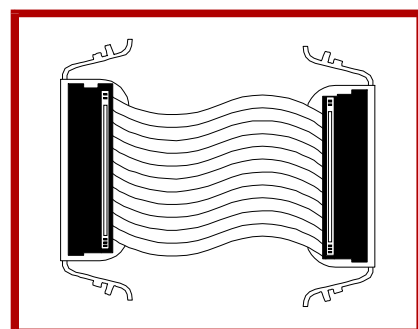
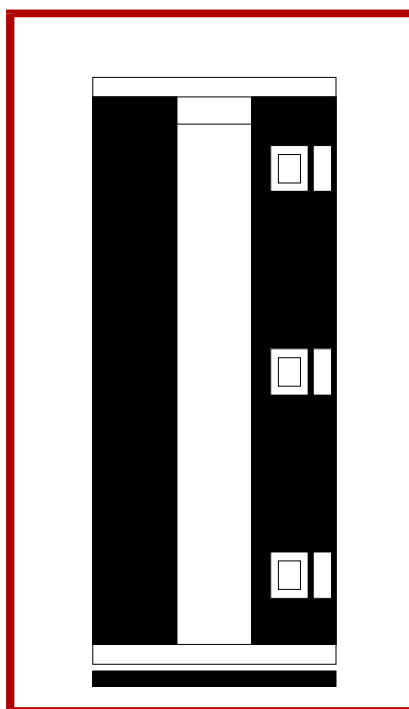
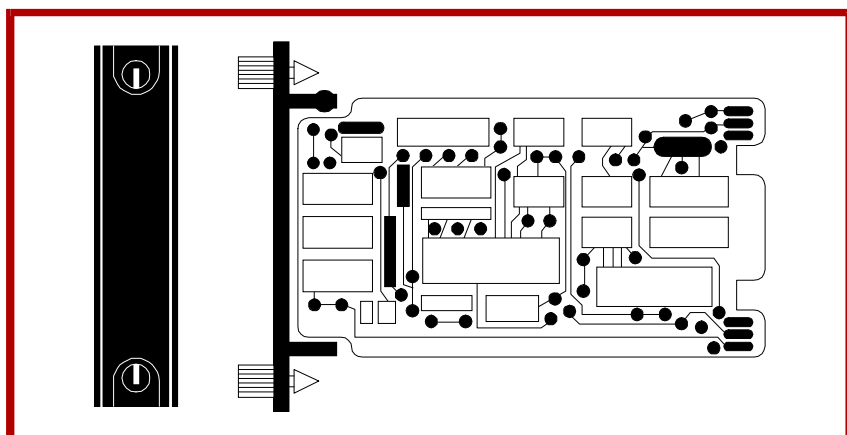
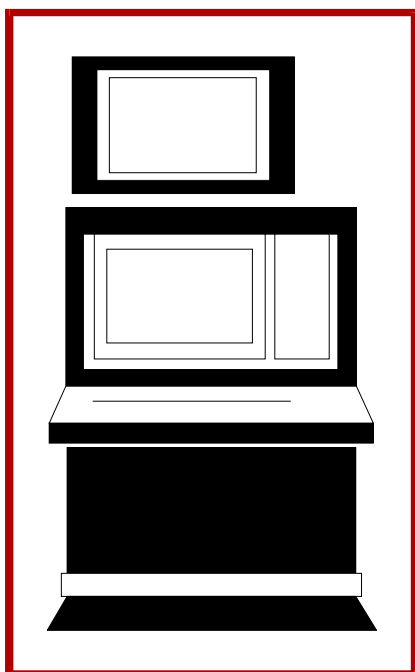

WARNING notices as used in this instruction apply to hazards or unsafe practices that could result in personal injury or death.

CAUTION notices apply to hazards or unsafe practices that could result in property damage.

NOTES highlight procedures and contain information that assists the operator in understanding the information contained in this instruction.

WARNING

INSTRUCTION MANUALS

DO NOT INSTALL, MAINTAIN, OR OPERATE THIS EQUIPMENT WITHOUT READING, UNDERSTANDING, AND FOLLOWING THE PROPER **Elsag Bailey** INSTRUCTIONS AND MANUALS; OTHERWISE, INJURY OR DAMAGE MAY RESULT.

RADIO FREQUENCY INTERFERENCE

MOST ELECTRONIC EQUIPMENT IS INFLUENCED BY RADIO FREQUENCY INTERFERENCE (RFI). CAUTION SHOULD BE EXERCISED WITH REGARD TO THE USE OF PORTABLE COMMUNICATIONS EQUIPMENT IN THE AREA AROUND SUCH EQUIPMENT. PRUDENT PRACTICE DICTATES THAT SIGNS SHOULD BE POSTED IN THE VICINITY OF THE EQUIPMENT CAUTIONING AGAINST THE USE OF PORTABLE COMMUNICATIONS EQUIPMENT.

POSSIBLE PROCESS UPSETS

MAINTENANCE MUST BE PERFORMED ONLY BY QUALIFIED PERSONNEL AND ONLY AFTER SECURING EQUIPMENT CONTROLLED BY THIS PRODUCT. ADJUSTING OR REMOVING THIS PRODUCT WHILE IT IS IN THE SYSTEM MAY UPSET THE PROCESS BEING CONTROLLED. SOME PROCESS UPSETS MAY CAUSE INJURY OR DAMAGE.

AVERTISSEMENT

MANUELS D'OPÉRATION

NE PAS METTRE EN PLACE, RÉPARER OU FAIRE FONCTIONNER L'ÉQUIPEMENT SANS AVOIR LU, COMPRIS ET SUIVI LES INSTRUCTIONS RÉGLEMENTAIRES DE **Elsag Bailey**. TOUTE NÉGLIGENCE À CET ÉGARD POURRAIT ÊTRE UNE CAUSE D'ACCIDENT OU DE DÉFAILLANCE DU MATÉRIEL.

PERTURBATIONS PAR FRÉQUENCE RADIO

LA PLUPART DES ÉQUIPEMENTS ÉLECTRONIQUES SONT SENSIBLES AUX PERTURBATIONS PAR FRÉQUENCE RADIO. DES PRÉCAUTIONS DEVRONT ÊTRE PRISES LORS DE L'UTILISATION DU MATÉRIEL DE COMMUNICATION PORTATIF. LA PRUDENCE EXIGE QUE LES PRÉCAUTIONS À PRENDRE DANS CE CAS SOIENT SIGNALÉES AUX ENDROITS VOULUS DANS VOTRE USINE.

PERTURBATIONS DU PROCÉDÉ

L'ENTRETIEN DOIT ÊTRE ASSURÉ PAR UNE PERSONNE QUALIFIÉE EN CONSIDÉRANT L'ASPECT SÉCURITAIRE DES ÉQUIPEMENTS CONTRÔLÉS PAR CE PRODUIT. L'AJUSTEMENT ET/OU L'EXTRACTION DE CE PRODUIT PEUT OCCASIONNER DES À-COUPS AU PROCÉDÉ CONTRÔLE LORSQU'IL EST INSÉRÉ DANS UNE SYSTÈME ACTIF. CES À-COUPS PEUVENT ÉGALEMENT OCCASIONNER DES BLESSURES OU DES DOMMAGES MATÉRIELS.

NOTICE

The information contained in this document is subject to change without notice.

Elsag Bailey, its affiliates, employees, and agents, and the authors and contributors to this publication specifically disclaim all liabilities and warranties, express and implied (including warranties of merchantability and fitness for a particular purpose), for the accuracy, currency, completeness, and/or reliability of the information contained herein and/or for the fitness for any particular use and/or for the performance of any material and/or equipment selected in whole or part with the user of/or in reliance upon information contained herein. Selection of materials and/or equipment is at the sole risk of the user of this publication.

This document contains proprietary information of Elsag Bailey, Elsag Bailey Process Automation, and is issued in strict confidence. Its use, or reproduction for use, for the reverse engineering, development or manufacture of hardware or software described herein is prohibited. No part of this document may be photocopied or reproduced without the prior written consent of Elsag Bailey.

Preface

The Configuration Port Module (IMCPM01) connects the Configuration and Tuning Terminal (CTT01/CTT02) to the INFI 90[®]/Network 90[®] system.

This manual explains the purpose, operation and maintenance of the CPM module. It addresses handling precautions and installation procedures.

System engineers and technicians should read this manual before installing and operating the CPM module. A module **SHOULD NOT** be put into operation until this instruction is read and understood.

List of Effective Pages

Total number of pages in this instruction is 18, consisting of the following:

Page No.	Change Date
Preface	Original
List of Effective Pages	Original
iii through v	Original
1-1 through 1-4	Original
2-1 through 2-2	Original
3-1 through 3-3	Original
4-1 through 4-2	Original
5-1	Original
6-1	Original

When an update is received, insert the latest changed pages and dispose of the superseded pages.

NOTE: On an update page, the changed text or table is indicated by a vertical bar in the outer margin of the page adjacent to the changed area. A changed figure is indicated by a vertical bar in the outer margin next to the figure caption. The date the update was prepared will appear beside the page number.

Safety Summary

**GENERAL
WARNINGS**

Equipment Environment

All components, whether in transportation, operation, or storage must be in a noncorrosive environment.

Electrical Shock Hazard During Maintenance

Disconnect power or take precautions to insure that contact with energized parts is avoided when servicing.

Sommaire de Securite

**AVERTISSEMENT
D'ORDRE GENERAL**

Environnement de l'Equipement

Ne pas soumettre les composants a une atmosphere corrosive lors du transport, de l'entreposage ou de l'utilisation.

Risques de chocs electriques lors de l'entretien

S'assurer de debrancher l'alimentation ou de prendre les precautions necessaires a eviter tout contact avec des composants sous tension lors de l'entretien.

Table of Contents

	<i>Page</i>
SECTION 1 - INTRODUCTION	1-1
OVERVIEW	1-1
INTENDED USER	1-2
MODULE DESCRIPTION	1-2
FEATURES	1-2
SECTION CONTENT	1-2
GLOSSARY	1-3
RELATED EQUIPMENT	1-3
RELATED DOCUMENTS	1-3
SPECIFICATIONS	1-4
SECTION 2 - DESCRIPTION AND OPERATION	2-1
INTRODUCTION	2-1
INPUTS AND OUTPUTS	2-1
Input and Output Circuit Description	2-1
Input and Output Circuit Connections	2-1
LOGIC POWER	2-2
MODULE BUS	2-2
SECTION 3 - INSTALLATION	3-1
INTRODUCTION	3-1
UNPACKING AND HANDLING	3-1
Special Handling	3-1
General Handling	3-1
SETUP AND INSTALLATION	3-1
Physical Installation	3-1
WIRING CONNECTIONS AND CABLING	3-2
Wiring	3-2
Cable Connections	3-2
FUSING	3-3
PRE-OPERATING ADJUSTMENTS	3-3
SECTION 4 - TROUBLESHOOTING	4-1
INTRODUCTION	4-1
ERROR INDICATIONS AND CORRECTIVE ACTION	4-1
MODULE REPLACEMENT	4-1
MODULE PIN CONNECTIONS	4-2
SECTION 5 - MAINTENANCE	5-1
INTRODUCTION	5-1
MAINTENANCE SCHEDULE	5-1
SECTION 6 - SUPPORT SERVICES	6-1
INTRODUCTION	6-1
REPLACEMENT PARTS AND ORDERING INFORMATION	6-1
TRAINING	6-1
TECHNICAL DOCUMENTATION	6-1

List of Tables

<i>No.</i>	<i>Title</i>	<i>Page</i>
4-1.	P1 Pin Connections	4-2
5-1.	Maintenance Schedule.....	5-1

List of Figures

<i>No.</i>	<i>Title</i>	<i>Page</i>
1-1.	IMCPM01 Application Example	1-1
2-1.	Configuration Port Module.....	2-1
2-2.	IMCPM01 Input/Output Circuit	2-2
3-1.	IMCPM01 Cable Connections and Termination	3-2
4-1.	IMCPM01 Fuse Location	4-2

SECTION 1 - INTRODUCTION

OVERVIEW

The Configuration Port Module (IMCPM01) connects the Configuration and Tuning Terminal (CTT01/CTT02) and the INFI 90/Network 90 system.

This manual explains the purpose, operation and maintenance of the Configuration Port Module (IMCPM01). It explains handling cautions and steps for installing the CPM. Figure 1-1 shows the INFI 90/Network 90 communication levels and where the CPM module is within these levels. Refer to the Configuration and Tuning Terminal Product Instruction Manual for more details about the CTT.

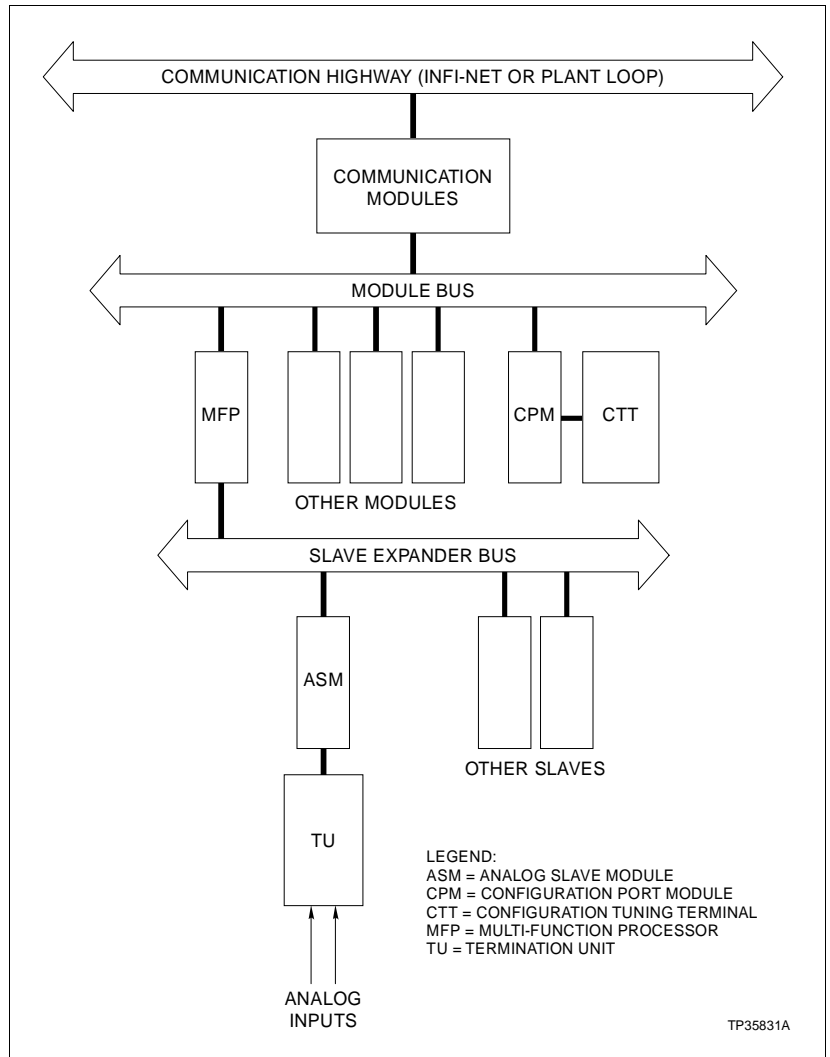

Figure 1-1. IMCPM01 Application Example

INTENDED USER

System engineers and technicians should read this manual before installing and operating the CPM module. A module **SHOULD NOT** be put into operation until this manual is read and understood. Refer to the **Table of Contents** to find needed data after the module is operating.

MODULE DESCRIPTION

The CPM has a single printed circuit board that takes up one slot in a Module Mounting Unit (MMU). It connects the Configuration and Tuning Terminal to the Network 90 module bus or the INFI 90 controlway on the back of the module mounting unit (MMU).

Two captive screws on the module faceplate secure it to the Module Mounting Unit (MMU). A five pin connector on the faceplate receives the plug from the CTT.

The CPM has one card edge connector for signals and power (P1). P1 connects to common (ground) and +5 VDC power through the MMU. Digital signals between the CTT and the master modules also pass through the P1 connector.

FEATURES

The modular design of the CPM module, as with all INFI 90 modules, allows for flexibility when you are creating a process management system strategy. It provides a fused power source to the CTT and a connection to the module bus.

NOTE: A CPM module can be removed or installed without powering down the system.

SECTION CONTENT

This manual has six sections. **Introduction** is an overview of the CPM module: features, description and specifications. **Description and Operation** explains the module operation and circuitry. **Installation** describes precautions to observe when handling CPM modules and setup procedures required before module operation. This section also describes the steps to install the CPM. **Troubleshooting** describes the error indications and how to correct them. **Maintenance** has a schedule for maintaining the module. **Support Services** explains how to order parts. It also explains other areas of support that Bailey Controls provides.

GLOSSARY

Term	Definition
CTT	Configuration Tuning Terminal; a hand held terminal providing a local means for system, configuration, monitoring, tuning and diagnostics.
Configuration	A control strategy with function blocks.
MMU	Module Mounting Unit; a card cage that provides electrical and communication support for INFI 90 modules.
Module Bus	A peer-to-peer communication path for point data transfer between intelligent modules within a process control unit.
PCU	Process Control Unit; rack type industrial cabinet that contains master, slave and communication modules, and their communication paths.

RELATED EQUIPMENT

The following modules and equipment can be used with a CPM module.

Module Number	Description
CTT01/02	Configuration and Tuning Terminal
IEMMU01/02	Module Mounting Unit

RELATED DOCUMENTS

Document Number	Description
I-E92-501-1	CTT01 Configuration and Tuning Terminal
I-E92-501-2	CTT02 Configuration and Tuning Terminal

SPECIFICATIONS

Mounting	Occupies one slot in a standard INFI 90 Module Mounting Unit (MMU).
Fuse Type:	0.5 Amp 250 Volt Bailey P/N 194776A15000 Littlefuse® 312.500 Buss™ AGC-1/2
Power Consumption	Power consumed is that of the CTT0_. CTT02 uses 85 mA at 5 VDC
Environmental Specifications	
Ambient Temperature:	0° to 70°C (32° to 158°F)
Relative Humidity:	5% to 90% up to 55°C (131°F) (noncondensing) 5% to 40% at 70°C (158°F) (noncondensing)
Atmospheric Pressure:	Sea level to 3 km (1.86 miles)
Air Quality:	Noncorrosive
Certification	CSA certified for use as process control equipment in an ordinary (nonhazardous) location.

SPECIFICATIONS SUBJECT TO CHANGE WITHOUT NOTICE

® Littlefuse is a registered trademark of Tracor Incorporated.
™ Bussman is a trademark of Bussman, Division of Cooper Industries.

SECTION 2 - DESCRIPTION AND OPERATION

INTRODUCTION

This section explains the circuits, power and connections for the Configuration Port Module (CPM). The CPM connects a Configuration Tuning Terminal (CTT) to the INFI 90/Network 90 system. The CTT hand held terminal allows you to configure, monitor, tune and run diagnostics on the system. The CTT connects with the system through the CPM (P1) and the module bus as shown in Figure 1-1. Figure 2-1 shows the schematic of a CPM.

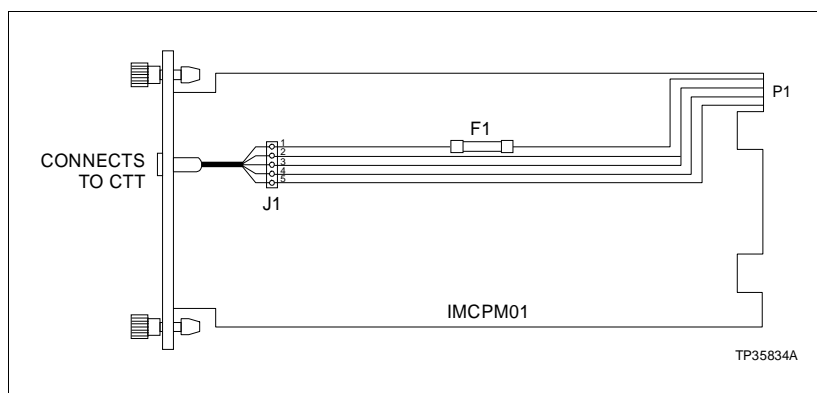

Figure 2-1. Configuration Port Module

INPUTS AND OUTPUTS

Digital signals to and from the CTT are +5 VDC. Section 3 explains the module connections.

Input and Output Circuit Description

Figure 2-2 shows the board circuitry on the CPM module. The board circuitry consists of signal traces and a 0.5 Amp fuse to protect the CTT and the system circuitry. The circuits provide 300 Volts isolation by using PCB trace separation to CSA standards.

Input and Output Circuit Connections

The input and output signals pass through the module bus and P1 to the connector on the front of the CPM. The CTT connects to the five pin connector on the front of the CPM with a five foot flexible cord.

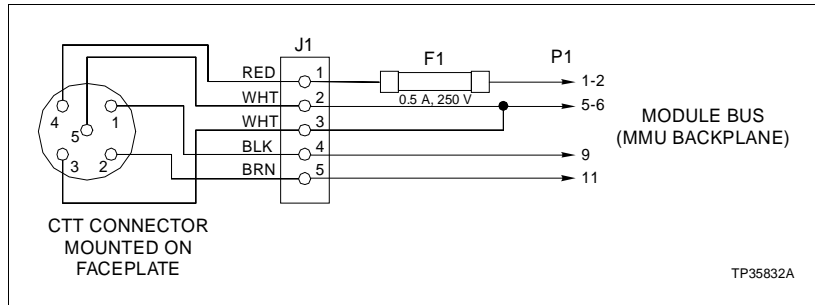

Figure 2-2. IMCPM01 Input/Output Circuit

LOGIC POWER

Logic power (+5 VDC) for the CTT circuits connects through the top 12-pin card edge connector (P1) shown in Figure 2-1.

MODULE BUS

The module bus provides a 83.3 kilobaud peer-to-peer communication link capable of supporting up to 32 drops.

SECTION 3 - INSTALLATION

INTRODUCTION

This section explains what you must do before you put the Configuration Port Module (IMCPM01) into operation. **DO NOT PROCEED** with operation until you read, understand and do the steps in the order in which they appear. Refer to the Configuration and Tuning Terminal Product Instruction Manual for more details about the CTT.

UNPACKING AND HANDLING

Special Handling

The CPM does not use electrostatic sensitive devices. No special handling is required.

General Handling

1. Examine the hardware when you receive it to verify that it has not been damaged in transit.
2. Notify the nearest Bailey Controls Sales Office of any shipping or handling damage.
3. File a claim for any damage with the company that handled the shipment.
4. Use the original packing and container to store the hardware.
5. Store the hardware in clean air that is free from temperature and moisture extremes.

SETUP AND INSTALLATION

Before installing, check to see that the fuse on the board is good. There are no jumpers or switches to set on the CPM.

Physical Installation

The CPM module inserts into a standard INFI 90 Module Mounting Unit (MMU) and occupies one slot. To install:

1. Align the module with the guide rails in the MMU. Gently slide the module in until the front panel is flush with the top and bottom of the MMU frame.

2. Lock the module in place by turning the two captive screws on faceplate one-half turn. The module is in place when the notch on each screw is vertical and the open end is pointing toward the center of the module.
3. Connect the CTT cable to the connector on the front of the CPM. Check the cable to see that it is seated.
4. If the CTT does not power up refer to [Section 4](#).

NOTE: A CPM module can be removed or installed without powering down the system.

WIRING CONNECTIONS AND CABLING

The CPM has one card edge connector (P1) to supply logic power and provide digital communications. It has a five pin connector on the faceplate to connect the CTT.

Wiring

Installing the module in the MMU connects the CPM to the +5 VDC logic power at P1. The +5 VDC is necessary to drive the CTT circuitry. It also connects P1 to the module bus/control-way for communication with the master modules. The P1 connection requires no additional wiring or cabling.

Cable Connections

The CPM connects to the CTT with the five foot flexible cord permanently attached to the CTT (see [Figure 3-1](#)).

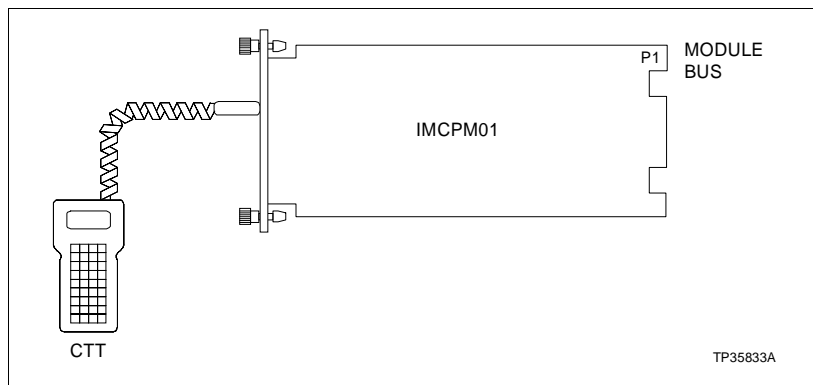

Figure 3-1. IMCPM01 Cable Connections and Termination

FUSING

The CPM has a 0.5 Amp on-board fuse. Use only a 0.5 Amp 250 Volt fuse Bailey P/N 194776A15000, Littlefuse P/N 312.500, Bussman AGC-1/2 or equivalent.

PRE-OPERATING ADJUSTMENTS

You do not have to make any adjustments to the CPM before operating.

SECTION 4 - TROUBLESHOOTING

INTRODUCTION

This section explains the error indications and corrective actions for the Configuration Port Module (IMCPM01).

ERROR INDICATIONS AND CORRECTIVE ACTION

The CTT01/02 receives power from module mounting unit. If the CTT loses power, follow the steps in this section. There are no active electrical components on the CPM. The only replaceable part is the 0.5 Amp 250 Volt fuse.

MODULE REPLACEMENT

NOTE: You can remove the CPM module while system power is supplied.

1. Remove the CTT cable from the connector in the CPM faceplate.

NOTE: When removing the CTT cable pull on the plug, not on the cable.

2. Lock the module by turning the two captive screws on faceplate one-half turn. The module is unlocked when the notch on each screw is vertical and the open end is pointing away from the center of the module.
3. Gently slide the module out of the module mounting unit.
4. Test the fuse to see if it is open. If the fuse is open continue with Step 5. If the fuse is good continue with Step 6.
5. If the fuse is open, remove it from the fuse holder (see Figure 4-1). Install a new fuse, use only a 0.5 Amp, 250 Volt fuse (Bailey Controls P/N 194776A15000).
6. Connect the CTT cable to the connector on the front of the CPM. Check the cable to see that it is seated.
7. Insert the module into the module mounting unit. Refer to [Section 3](#) for the procedures to install a module.
8. If the CTT does not power up, it needs to be checked. Refer to the CTT Product Instruction for troubleshooting and repair information.

NOTE: If the CPM is faulty, replace it with a new one.

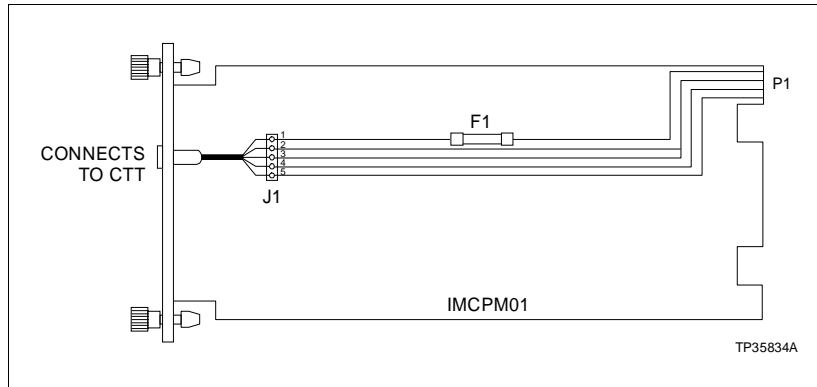

Figure 4-1. IMCPM01 Fuse Location

MODULE PIN CONNECTIONS

The CPM module has one connection point for external signals and power (P1). Table 4-1 shows the P1 pin connections.

Table 4-1. P1 Pin Connections

Pin	Connection	Pin	Connection
1	+5 VDC	7	NC ¹
2	+5 VDC	8	NC ¹
3	NC ¹	9	Power Fail Interrupt
4	NC ¹	10	NC ¹
5	Common	11	Module Bus
6	Common	12	NC ¹

1. Not Connected.

SECTION 5 - MAINTENANCE

INTRODUCTION

The Configuration Port Module (IMCPM01) requires limited maintenance. This section contains a schedule to maintain the CPM.

MAINTENANCE SCHEDULE

Do the tasks in Table 5-1 at the noted times.

Table 5-1. Maintenance Schedule

Task	Interval
Clean and tighten all power and grounding connections. Check fuses and holders.	Every 6 months or during plant shut-down, whichever occurs first.
Use a static safe vacuum cleaner to remove dust from: Modules Module Mounting Unit Fan Assembly	Every 6 months or during plant shut-down, whichever occurs first

SECTION 6 - SUPPORT SERVICES

INTRODUCTION

Bailey Controls is ready to help in the use and repair of its products. Contact your nearest sales office to make requests for sales, repair and maintenance contracts.

REPLACEMENT PARTS AND ORDERING INFORMATION

When making repairs at your plant, order parts from a Bailey Controls sales office. Please provide this information:

1. Part description, part number and quantity.
2. Model and serial numbers (if used).
3. Bailey Controls manual number, page number and figure that shows the part.

When you order standard parts from Bailey Controls, use part numbers and descriptions from the Spare Parts Lists. You must order parts without descriptions from the nearest Bailey Controls sales office.

TRAINING

Bailey Controls has a modern training center that provides service and repair classes. We can provide in-plant training of your personnel. Contact a Bailey Controls sales office for specific information and scheduling.

TECHNICAL DOCUMENTATION

You can obtain additional copies of this manual from the nearest Bailey sales office at a reasonable charge.

Visit Eltag Bailey on the World Wide Web at <http://www.bailey.com>

Our worldwide staff of professionals is ready to meet *your* needs for process automation.
For the location nearest you, please contact the appropriate regional office.

AMERICAS

29801 Euclid Avenue
Wickliffe, Ohio USA 44092
Telephone 1-216-585-8500
Telefax 1-216-585-8756

ASIA/PACIFIC

152 Beach Road
Gateway East #20-04
Singapore 189721
Telephone 65-391-0800
Telefax 65-292-9011

EUROPE, AFRICA, MIDDLE EAST

Via Puccini 2
16154 Genoa, Italy
Telephone 39-10-6582-943
Telefax 39-10-6582-941

GERMANY

Graefstrasse 97
D-60487 Frankfurt Main
Germany
Telephone 49-69-799-0
Telefax 49-69-799-2406